



Sydney
 0416040076
 mobileauto@bigpond.com
 mobileautomotivesolutions.com.au

Mobile Automotive Solutions PTY LTD

Tax Invoice

Bill To: Scout Fleet / Will Davies
 kristine@carnextdoor.com.au, scoutfleetptyltd@gmail.com, will@carnextdoor.com.au

Invoice No: APP4446
Date: 24/04/2024
Due Date: 24/04/2024

REGO: SUM71T **YEAR:** 2018
MAKE: Hyundai **ODO:** 94722
MODEL: I30

Description	Quantity	Rate	Amount
Engine oil flush, service overdue	1	\$27.00	\$27.00
5w30 Full syn engine oil	4	\$20.00	\$80.00
Oil filter	1	\$22.00	\$22.00
Air filter element	1	\$42.00	\$42.00
Workshop consumables, solvents, sundries and waste oil disposal.	1	\$15.00	\$15.00
Labour on service: -Check all the lights. -Clean the air filter, when can. -Check or top up fluids. -Adjustments where needed. -Tighten bolts where needed. -Check Tyre pressures. -Visual inspection. -Test drive.	1	\$118.18	\$118.18
Cabin filter (supply and fit)	1	\$65.00	\$65.00
Cooling system flush and test	1	\$145.00	\$145.00
Envirotek fuel system treatment and cleaner, additive (petrol)	1	\$30.00	\$30.00

Description	Quantity	Rate	Amount
Battery (supply and fit) XDIN66HMF	1	\$280.00	\$280.00
Payment Details			
Mobile Automotive Solutions PTY LTD		Subtotal	\$824.18
BSB: 032159 ACC: 376786		GST 10%	\$82.42
		Total	\$906.60
ABN: 35168714029		PAID	\$0.00
Balance Due			\$906.60

Notes

At the next service or sooner:
The boot relief switch is broken.

The front and rear brake pads need replacing ASAP.

The TPMS light was on, but it went away as soon as I inflated the tyres.

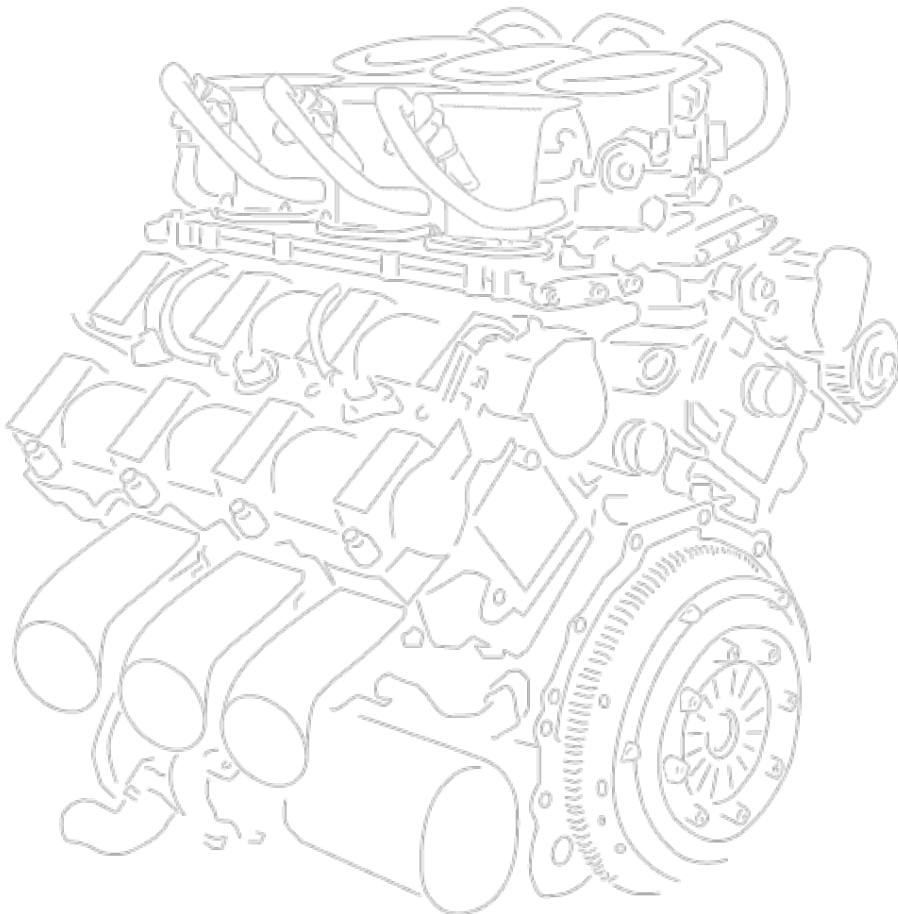

Photo 1

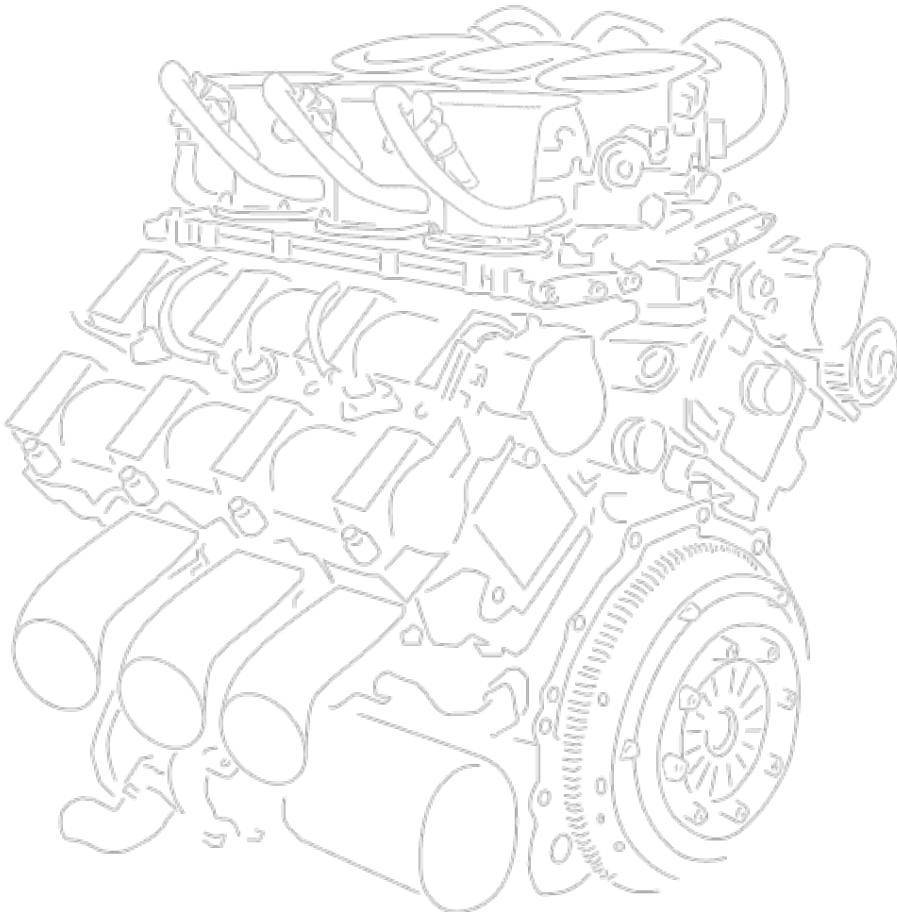

Photo 2

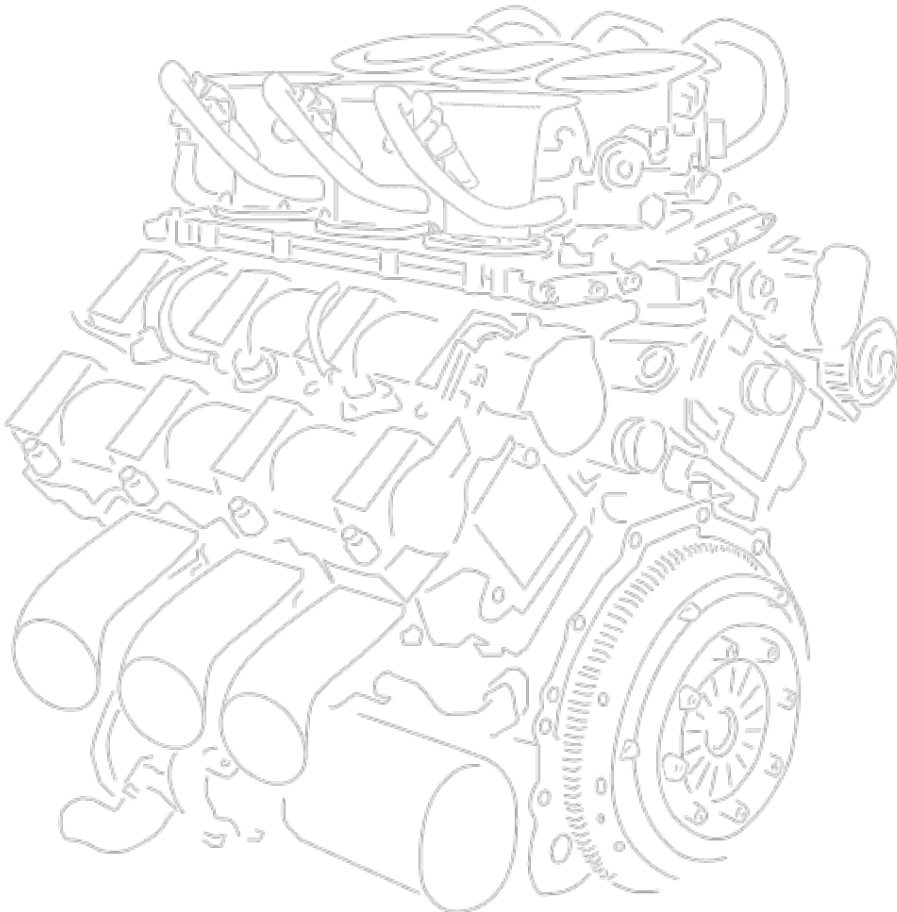

Photo 3

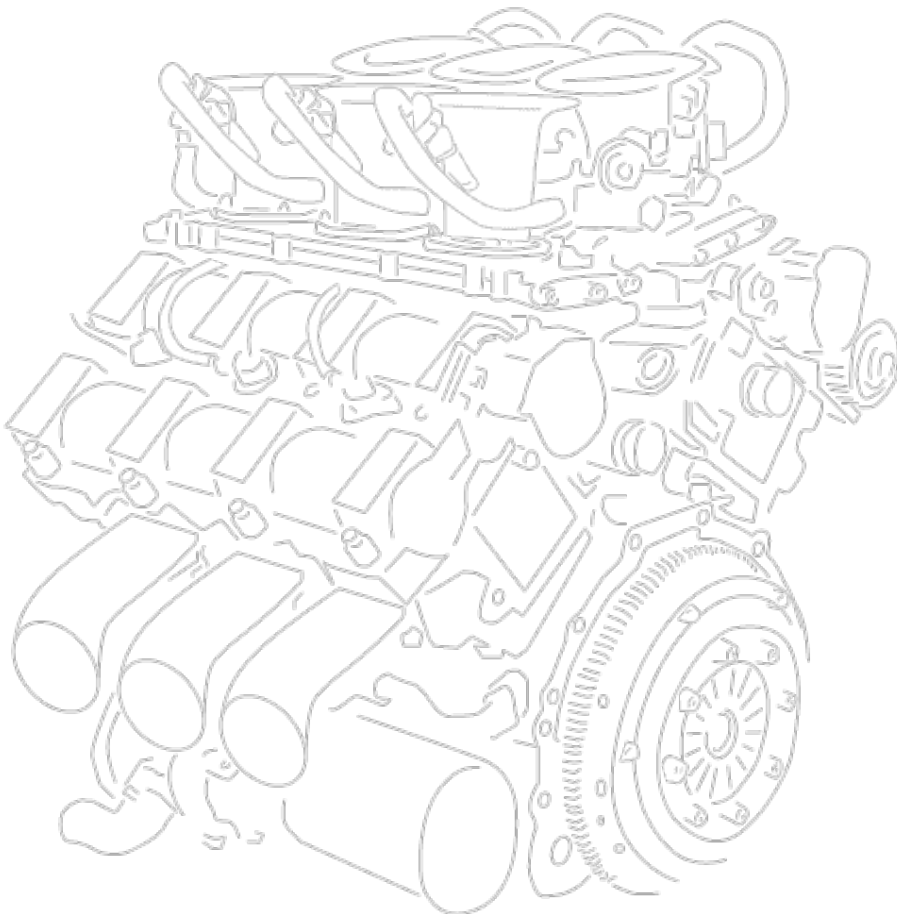

Photo 4

